

## Top Mounted Aluminum Block & Cover System

### DTA71-GLS

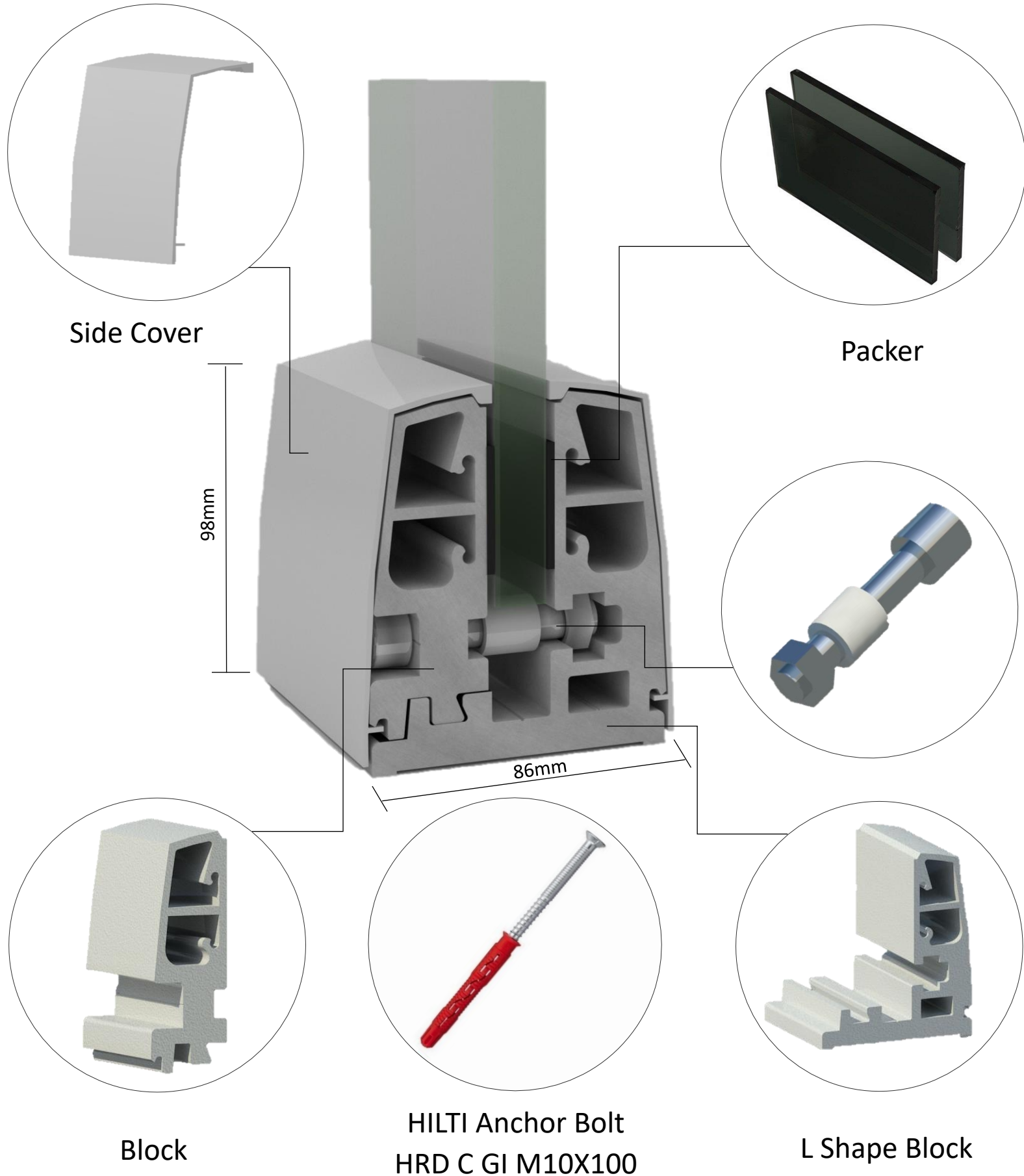

## Specification



### Block :

- Material: AL6063 T6
- Length: 75mm
- Height: 98mm
- Width: 86mm
- Approx Weight: 0.710 KG / Nos



### Cover :

- Material: AL6063 T6
- Length: 12 Feet & 16 Feet
- Approx Weight: 2.85 KG / 16 Feet



### Packer :

- Material : ABS / M28RC / Nylon 6



### Anchor Fastner:

- Type : Hilti HRD C GI M10X100/120/140/160 (Counter Sunk) (As per client's requirement)



### Powder Coating:

- Type : AkzoNobel
- Color / Shade: As per client preference and subject to availability and feasibility
- Coat Thickness: 80-100 Microns
- Coating Warranty: 10 years of AkzoNobel Warranty

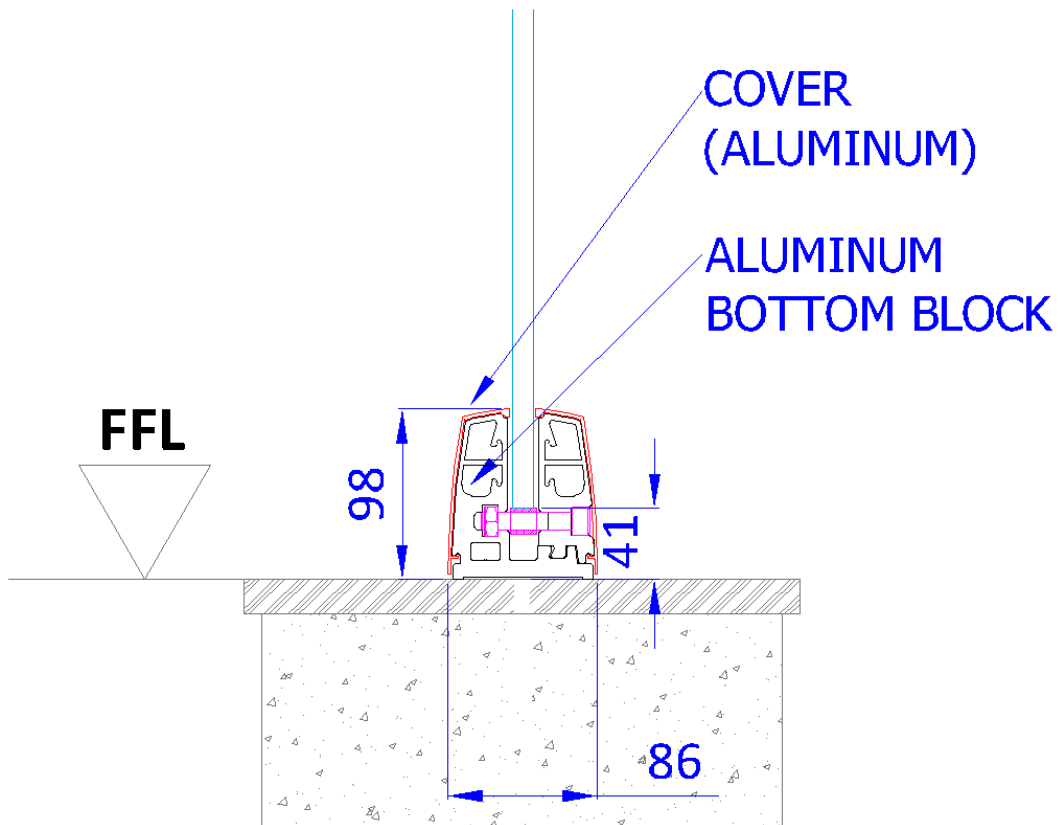

**SIDE VIEW**